

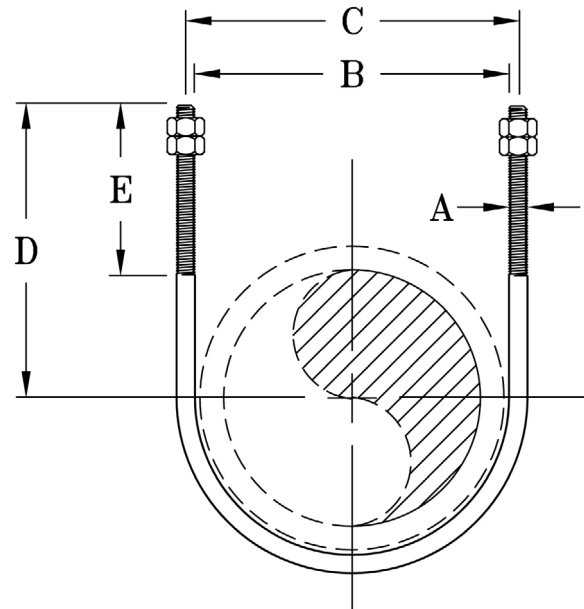

FIG. 100

LONG TANGENT U-BOLT

www.pipingtech.com/fig100

- MATERIAL:** Carbon steel
- FINISH:** Black. Galvanized upon request.
- ORDERING:** Specify figure number, pipe size, description and finish, if other than black.
- NOTE:**
- U-Bolts are furnished with four hexagon nuts or are furnished with two hexagon nuts.
 - Special U-Bolts with longer tangents and threads and special materials can be furnished as specified.



SUPPORT ASSEMBLY COMPONENTS

PIPE SIZE	MAX. RECOM. LOAD (lb.)	A	B	C	D	E	WEIGHT (lb. per 100)
1/2	580	1/4	7/8	1 1/8	2 1/2	2 1/2	12
3/4	580	1/4	1 1/8	1 3/8	2 5/8	2 1/2	13
1	580	1/4	1 3/8	1 5/8	2 3/4	2 1/2	14
1 1/4	1,460	3/8	1 3/4	2 1/8	2 7/8	2 1/2	38
1 1/2	1,460	3/8	2	2 3/8	3	2 1/2	39
2	1,460	3/8	2 1/2	2 7/8	3 1/4	2 1/2	42
2 1/2	2,700	1/2	3	3 1/2	3 3/4	3	90
3	2,700	1/2	3 5/8	4 1/8	4	3	99
3 1/2	2,700	1/2	4 1/8	4 5/8	4 1/4	3	109
4	2,700	1/2	4 5/8	5 1/8	4 1/2	3	115
5	2,700	1/2	5 5/8	6 1/8	5	3	128
6	4,320	5/8	6 3/4	7 3/8	6 1/8	3 3/4	239
8	4,320	5/8	8 3/4	9 3/8	7 1/8	3 3/4	283
10	6,460	3/4	10 7/8	11 5/8	8 3/8	4	479
12	9,960	7/8	12 7/8	13 3/4	9 5/8	4 1/4	764
14	9,960	7/8	14 1/8	15	10 1/4	4 1/4	820
16	9,960	7/8	16 1/8	17	11 1/4	4 1/4	870
18	11,800	1	18 1/8	19 1/8	12 5/8	4 3/4	1,350
20	11,800	1	20 1/8	21 1/8	13 5/8	4 3/4	1,460
24	11,800	1	24 1/8	25 1/8	15 5/8	4 3/4	1,710
30	11,800	1	30 1/8	31 1/8	18 5/8	4 3/4	1,920
36	11,800	1	36 1/8	37 1/8	21 5/8	4 3/4	2,326

SCOMPONENTS04.XLS-07/01/09