



FIG. 1000

BOLT CRADLE SUPPORT WITH BONDED/BOLTED SLIDE PLATE CRADLED NON-GUIDED SUPPORT

www.pipingtech.com/fig1000

- MATERIAL:** Carbon steel
- FINISH:** Painted or hot dipped galvanized.
- OPTIONS:** Modifications in the dimensions A, B, C, D, and the slide plate material (PTFE, 25% glass filled or graphite) available upon request.
- ORDERING:** Specify figure number, pipe size, description, type, quantity, finish and slide plate material.
- ALLOWABLE LOADS:** The allowable vertical loads depend upon the pipe pressure and wall thickness.
- BONDING:** Graphite slide plates are usually bonded. For high temperature service above 500 °F specify bolted construction.

BOLTED BASE

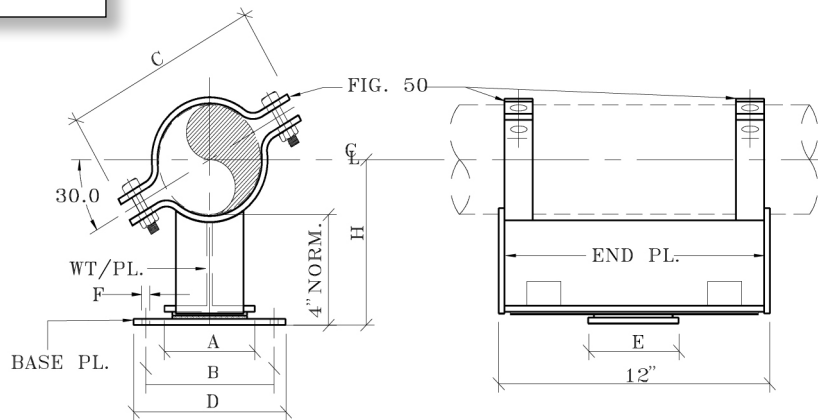

PIPE SIZE	A	B	C	D	E	F	H
2	4	16	5 1/2	18	5	13/16	5 3/16
2 1/2	4	16	6 3/8	18	5	13/16	5 7/16
3	4	16	7	18	5	13/16	5 3/4
4	4	16	8 9/16	18	5	13/16	6 1/4
5	4	16	9 11/16	18	5	13/16	6 13/16
6	4	16	11 5/8	18	5	13/16	7 5/16
8	4	16	13 7/8	18	5	13/16	8 5/16
10	4	16	17	18	5	13/16	9 3/8
12	4	16	18 15/16	18	5	13/16	10 3/8
14	4	16	21	18	5	13/16	11
16	4	16	23	18	5	13/16	12
18	7	18 1/2	25 7/8	21	5 1/2	15/16	13
20	7	18 1/2	28	21	5 1/2	15/16	14
24	7	18 1/2	33 1/2	21	5 1/2	15/16	16

PIPESH0ES01.XLS-07/17/09