



FIG. 40

WELDLESS EYE NUT

 www.pipingtech.com/

MATERIAL: Forged steel

SERVICE: For use on high temperature piping installations.

FEATURES:

- Supports loads equal to the full limitation of the hanger rod.
- Provides flexible connection when used with straight thread rods.

ORDERING: Specify figure number, rod size, description, rod tapping and finish.

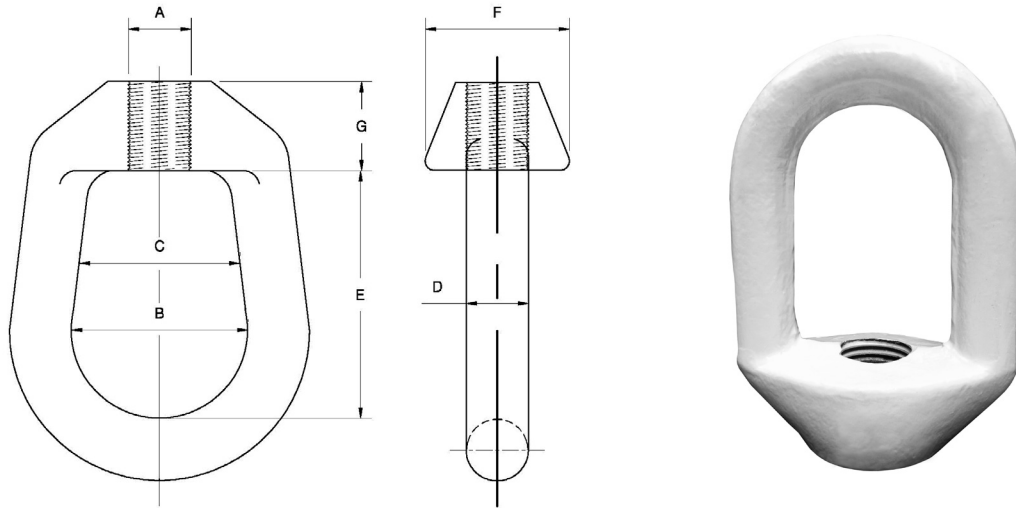

SUPPORT ASSEMBLY COMPONENTS

SIZE NO.	ROD SIZE A	MAX. RECOM. LOAD (lb.)		B	C	D	E	F	G	APPROX. WEIGHT (lb. per 100)
		@ 650 °F	@ 750 °F							
1	3/8	730	572	1 1/2	1 3/16	1/2	2	1 3/8	11/16	68
	1/2	1,350	1,057							69
	5/8	2,160	1,692							66
	3/4	3,230	2,530							59
2	7/8	4,480	3,508	2	1 11/16	3/4	2 5/8	1 15/16	1	170
	1	5,900	4,620							170
3	1 1/8	7,660	5,560	2 1/2	1 13/16	1	3 3/8	2 3/8	1 1/4	380
	1 1/4	9,500	7,440							380
	1 1/2	13,800	10,807							350
4	1 3/4	18,600	14,566	4	4	1 1/2	6 1/4	4	2 1/4	1890
	2	24,600	19,265							1890
	2 1/4	32,300	25,295							1800
	2 1/2	39,800	31,169							1660

SCOMPONENTS04.XLS-09/02/11