

TECHNICAL BULLETIN



MATERIAL SPECIFICATIONS Benefits Of G10 Micarta® For Insulation



PIPING TECHNOLOGY & PRODUCTS, INC.

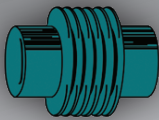

U.S. Bellows, Inc.



SWECO FAB



Pipe Shields Inc.



Anchor/Darling
Enterprises, Inc.

website: pipingtech.com

email: info@pipingtech.com

TECHNICAL BULLETIN

Benefits Of G10 Micarta® For Insulation

G10 Micarta® can be very cost-effective insulation as compared to Polyurethane foam (PUF), especially for medium and large shoes. It offers tremendous benefits at various stages of a project, including but not limited to:

- Procurement
- Installation
- Handling, transportation, and storage
- Plant Maintenance



Cryogenic Pipe Supports with Micarta® Insulation for an LNG Plant

MAJOR ADVANTAGE OF G10 MICARTA® SUPPORTS FOR PROCUREMENT

G10 Micarta® supports involve fewer steps to manufacture, allowing for a quicker fabrication turnaround. It takes 2-3 weeks less on average than PUF supports for delivery. This enables the ability to catch up on deadlines and reduce downtime.

- G10 Micarta® shoes cost less than PUF shoes of the same size, meaning *Low Capital Expenses*:

Pipe Support Standard(PUF)	Pipe Nominal x Insulation thk	G10 Micarta Cost Savings
CA1_24_E_2_32	24"x211	49%
CA2_12_D_7.5_24	12"x7.5"	56%
CA2_24_D_8_24	24"x8"	68%
CA2_30_E_4.5_24	30"x4.5"	35%
CA6_36_A_2.5_10.5_24	36"x2.5"	37%
CS2_42_8_32	4211x8"	42%
CS3_24_9_14	24"x9"	46%
CS6_36_8_16_14	36"x8"	17%
CS6_42_4_12_30	42"x4"	21%
CS6_42_5_13_30	4211x5"	25%
CS6_48_2.5_10.5_30	4811x2.511	19%
CS6_48_5_13_30	48"x5"	19%

ADVANTAGES OF G10 MICARTA® SUPPORTS DURING CONSTRUCTION/ INSTALLATION

G10 shoes can be sent to the pipe fabricator and can weld directly to the pipe spool, meaning there is minimal installation in the field. It takes 3-5 hours to install a PUF shoe in-field, depending on the size. G10 Micarta® shoes save that FIELD installation time.



Micarta® Block Assemblies for Placement Beneath a Saddle Support of a Vessel

Shop welding of G10 Micarta® shoes is much cheaper. As G10 shoes are weld to pipe spool at the fabricator's shop, they can be inspected and tested in the shop; no inspection and testing in the field. More cost savings as inspection and testing is done at cheaper rates at pipe spool fabricator facilities rather than in the field.



As G10 Micarta® shoes are handled along with the pipe spools, there are fewer chances of missing supports in the field. Less OS&Ds to worry about for both the client and supplier.

TECHNICAL BULLETIN

MAJOR ADVANTAGE OF G10 MICARTA® SUPPORTS WHILE HANDLING, TRANSPORTATION & STORAGE

G10 Micarta® supports are less fragile than PUF, making the handling, transportation, and storage of G10 to be trouble-free. No special packaging required, saving the time & the cost of special crating. Stronger G10 supports reduce the chances of accidental damage, thereby the need to re-fabricate the support.



Cryogenic Pipe Supports with Micarta® G10 Insulation, and Axial Stops for an LNG Facility

G10 Micarta® supports have insignificant water/moisture absorption rate, this means:

- No structural deterioration in adverse weather, especially in the wake of heavy rain and storms. PUF deteriorates in wet weather or humid climates
- Better life of the support
- Less maintenance and more saving

	G10 Micarta	PUF (20 pcf)
Density	119 lbs/ft ³ / 0.069 lbs/in. ³	20 lbs/ft ³ / 0.012 lbs/in. ³
Maximum Operating Temperature		
Mechanical :	-300 °F to 284 °F (140°C)	-300 °F to Ambient (-184 °C to Ambient)
Water Absorption	≤ 0.1%	0.13% to 0.22%, depending on density
Hardness (Rockwell M)	109	
Compressive Strength	60,000 psi	500 psi
Tensile Strength		300 psi
	LW : 40,000 psi	
	CW : 35,000 psi	
Flexural Strength		
	LW : 55,000 psi	1100 psi
	CW : 45,000 psi	
Impact Strength (Izod CW with grain)	12.0 ft-lb./in.	
Dielectric Strength	550 vpm	
Dielectric Constant (@ 10 ⁵ cycles per second)	5	
Volume Resistivity	6 x 10 ⁶ megohm-cm	
Arc Resistance	100 seconds	
Surface Resistivity	1 x 10 ⁶ megohms	
Parallel Dielectric	60 kv	

TESTING OF G10 MICARTA® SUPPORT

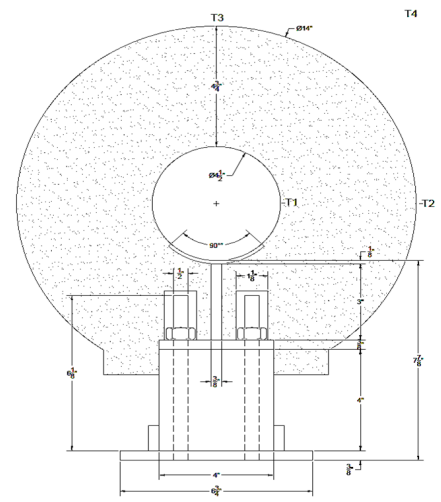
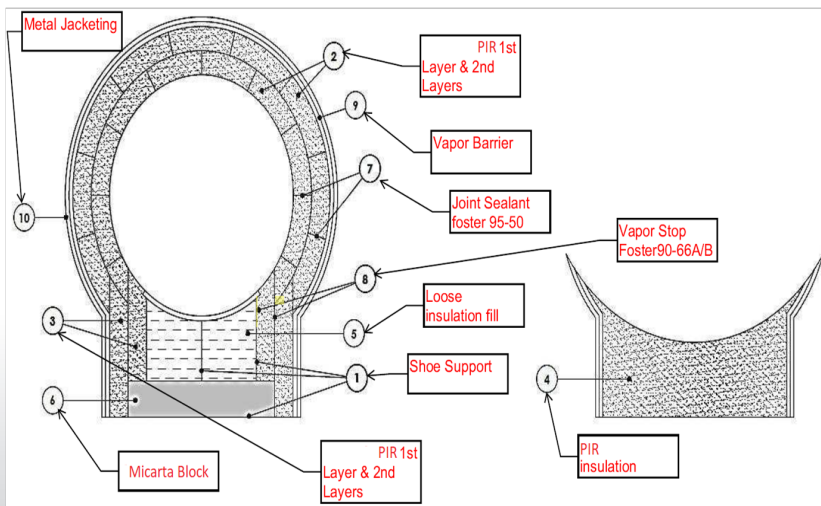

PT&P
Piping Technology & Products, Inc.

email: info@pipingtech.com
website: pipingtech.com

Copyright © 2019 Piping Technology & Products, Inc.

TECHNICAL BULLETIN

DATA SHEET					
MATERIAL USED: PIR INSULATION					
DATE:		ENGINEER:			
TIME	T1 (°F)	T2 (°F)	T3 (°F)	T4 (°F)	DEW POINT (°F)
3:00PM	-309	85	85	87	63
4:00PM	-302	84	84	85	62
5:00PM	-304	82	82	84	65
6:00PM	-305	78	78	82	
7:00PM	-300	76	76	80	
8:00PM	-302	75	75	78	
9:00PM	-300	73	73	78	
10:00PM	-306	71	73	76	
11:00PM	-306	71	73	76	
12:00AM	-306	71	73	76	
1:00AM	-300	71	71	76	
2:00AM	-306	71	71	76	
3:00AM	-306	71	73	75	
4:00AM	-306	71	71	75	
5:00AM	-306	71	71	75	
6:00AM	-306	73	75	78	
7:00AM	-308	75	78	80	61
8:00AM	-306	78	80	84	
9:00AM	-308	82	84	85	
10:00AM	-306	85	85	87	
11:00AM	-306	85	85	87	
12:00PM	-306	85	87	89	
1:00PM	-306	85	85	89	
2:00PM	-308	85	85	89	65
MEAN	-305.17	77.25	78.04	81.12	
STD DEV	2.55	5.94	5.75	5.16	

Table 1: Data Sheet

COMPARISON OF G10 MICARTA® VS. PUF FROM PREVIOUS TEST REPORTS:

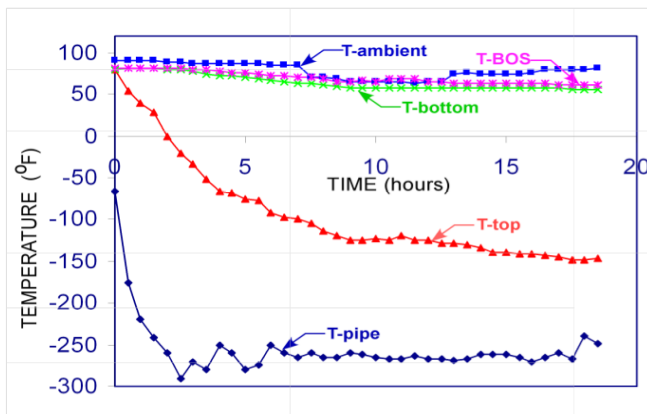

Time-dependent temperature variations at the stated locations using G-10 Micarta®.
(i) T-pipe; (ii) T-top; (iii) T- ambient; (iv) T-Bottom, (v) T-BOS.

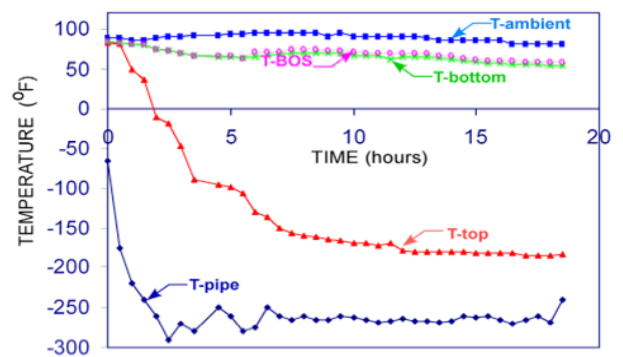

Time-dependent temperature variations at the stated locations using Polyurethane.
(i) T-pipe; (ii) T-top; (iii) T- ambient; (iv) T-Bottom, (v) T-BOS.